

# MİTES MTS-50 MN FUEL METER

## TECHNICAL DATA

- ◆ **Product Type:** Gasoline-Kerosene-Diesel
- ◆ **Flow Rate (Min):** 175 lpm
- ◆ **Flow Rate (Max):** 1750 lpm
- ◆ **Operation Temperature:** -40°C / +70°C
- ◆ **Counter Register:** Mechanical-MC 01
- ◆ **Weight:** 70 kg
- ◆ **Dimensions (WLH):** 640x760x720 mm
- ◆ **Flange Diameter:** 4"
- ◆ **Meter Body:** Cast Iron (PIG GG25)

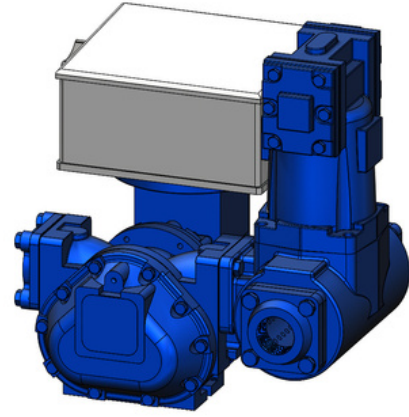
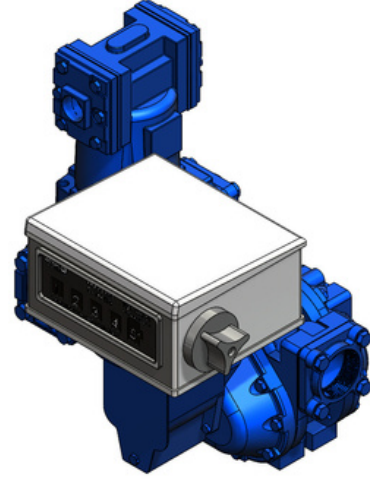

The MTS-50 model fuel meter, produced by the MİTES brand, one of the MLB Group companies, is a meter with positive displacement and high measurement accuracy. It is designed to be used safely wherever fuel oil measurement is required. When the usage and maintenance instructions are followed, it can be used for many years without any problems and accurate measurements can be taken.

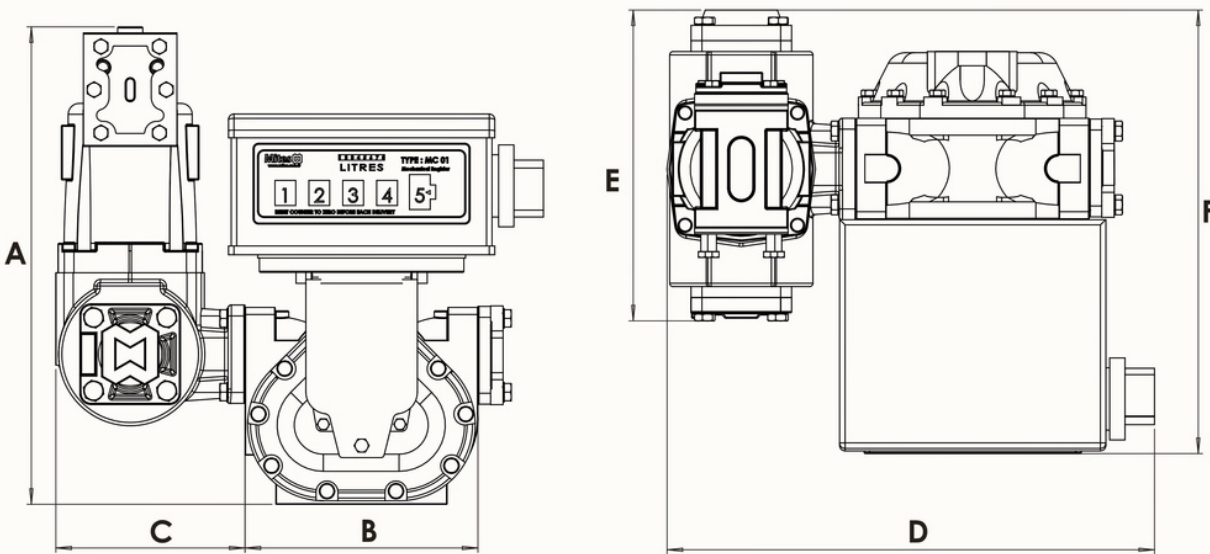

DIMENSIONS (mm)	A	B	C	D	E	F
	720	400	300	760	440	640